

CATV - WDM

4 PORT & 8 PORT SERIES HIGH POWER OPTICAL AMPLIFIER

PERFORMANCE CHARACTERISTICS

- Erbium co-doped double-clad fiber technology;
- Built-in low-noise preamplifier eliminates the need for EDFA cascading, greatly reducing system CNR and MER degradation;
- Output total power range: up to 23dBm~37dBm (5W) optional;
- Output power adjustable range +0.5~-4dBm;
- Perfect network management interface, in line with SNMP network management protocol;
- Adopts a mature dual-power hot backup structure dedicated to servers, and cooperates with a microcomputer-controlled intelligent temperature control system to effectively improve system reliability;
- Adopt 144*32 blue dot matrix LCD display to realize parameter on-site monitoring;
- The front panel indicator monitors and instructs the operating status of the equipment parameters in real time. Easy to find problems in time;
- Output port optional: SC connector 4 ~ 16 optional; LC connector 8 ~ 32 optional, optional WDM;
- The back panel can be flexibly removed and replaced according to the number of output ports



APPLICATIONS

- The **REVO EDFA-WDM** series high-power optical amplifier is a high-power multi-port output fiber amplifier with a gain spectrum bandwidth of 1535~1565nm. It is mainly designed for applications of CATV or 1~8 continuous strip channels (ITU wavelengths). It provides a flexible, low-cost solution for large-scale FTTH coverage of CATV systems in large and medium-sized cities.
- **REVO EDFA-WDM** can achieve single-wavelength cable TV transmission, CWDM single-fiber three-wave, flat gain, DWDM; its reliable and excellent performance ratio between the main application of FTTH, FTTB, DBS, MMDS, FTTX pon, is to build CATV large Medium-sized optical fiber transmission network is an important equipment.

DIAGRAM

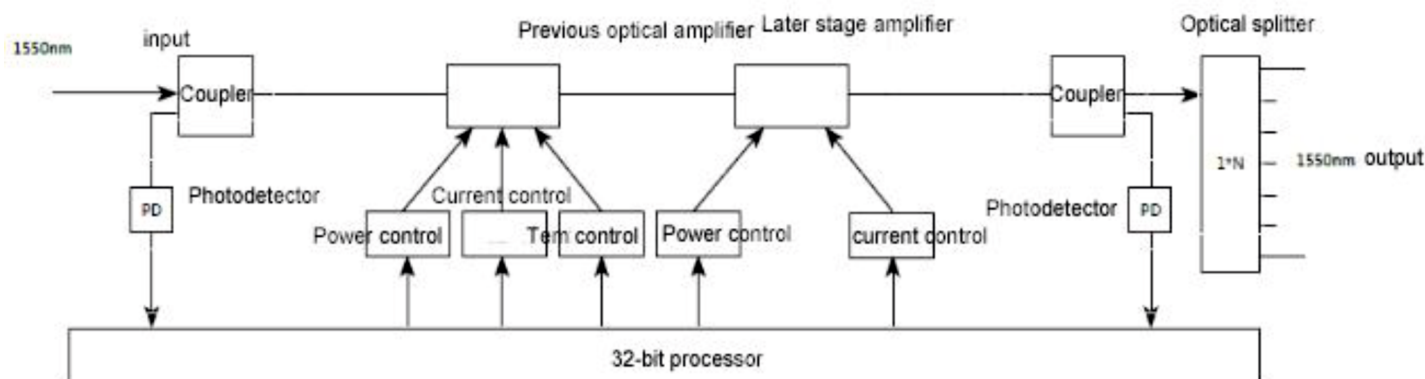

LIMIT PARAMETER

TECHNICAL PARAMETER	REVO EDFA-WDM
Maximum received range	1535-1565nm
Lowest input optical power	-5dBm
The highest input optical power	+10dBm
Extreme operating temperature	-5°C ~+42°C
Limit supply voltage	AC160~265V&DC90~130V&DC38~58V

TECHNICAL PARAMETER

TECHNICAL PARAMETER	REVO EDFA-WDM
Wavelength	1535-1565nm
Input power range	-5dBm~+10dBm (normal input +3dBm)
Output optical power	26dBm~37dBm
Optical power stability	±0.1dBm
Noise figure	≤ 5.0dB (Pin=0dB)
Input return loss	≥ 45dB
Output return loss	≥ 45dB
C/N	≥ 50dB
C/CTB	≥ 63dB
C/CSO	≥ 63dB
Optical connector	SC/APC; SC/PC; LC/APC; LC/PC
Supply voltage	AC220V(160V ~ 265V) /AC110V (90 ~130V) /DC48V (38 ~ 58V)
Consumption	≤ 50w
Working temperature	-5°C ~+42°C
Storage temperature	-30°C ~ +70°C
Maximum working relative humidity	Max 95% non-condensing
Size	357(W)*482(L)*44(H)mm
Package size (1pc)	595(W)*490(L)*120(H)mm
Package size (2pcs)	595(W)*490(L)*230(H)mm